

SHOCK OWNER'S MANUAL **PODIUM X**
MINI-MOTO APPLICATIONS

FOX
RACING SHOX



NOTICE: THE MOTORCYCLES PICTURED IN THIS MANUAL MAY OR MAY NOT RESEMBLE YOUR ACTUAL MOTORCYCLE. IN ANY CASE, THE PROCEDURES OUTLINED WILL CORRECTLY ENABLE YOU TO SET UP, MOUNT AND TUNE THE FOX PODIUM X TO YOUR PARTICULAR MODEL.



DENOTES INFORMATION THAT, IF NOT FOLLOWED, CAN CAUSE DAMAGE TO YOUR SHOCK OR LEAD TO SERIOUS INJURY OR DEATH.



DENOTES INFORMATION THAT MAY NOT BE OBVIOUS, OR THAT CAN HELP THE RIDER OUT WITH A DIFFICULT SITUATION.

TABLE OF CONTENTS

- CONGRATULATIONS!**2
- CONSUMER SAFETY**2
- SETTING UP THE PODIUM X**2
 - CHANGING SPRINGS 2
 - READING THE SPRING RATE 2
 - SPRING ORIENTATION 3
- MOUNTING THE PODIUM X**3
 - MEASURING AND SETTING RIDER SAG 5
 - MEASURING AND SETTING FREE SAG 6
 - ADJUSTING SPRING PRELOAD 7
- TUNING THE PODIUM X**7
 - TUNING RECOMMENDATIONS 8
 - REBOUND DAMPING 8
 - COMPRESSION DAMPING 9
- INSPECTING AND MAINTAINING THE PODIUM X**10
- TUNING NOTES** 11
- QUICK REFERENCE GUIDE**13

PODIUM X	
features	<ul style="list-style-type: none"> > Lightweight > Race-proven oil damping system > External rebound damping adjuster > External compression damping adjuster > 100% rebuildable and revalveable > 1-Year factory limited warranty > 90-day valving guarantee > Easy to install (no frame modifications)
kit contents	1: PODIUM X Shock with spring 1: Owner's Manual 2-4: Reducers (model specific) 2-4: O-rings (model specific) Decals

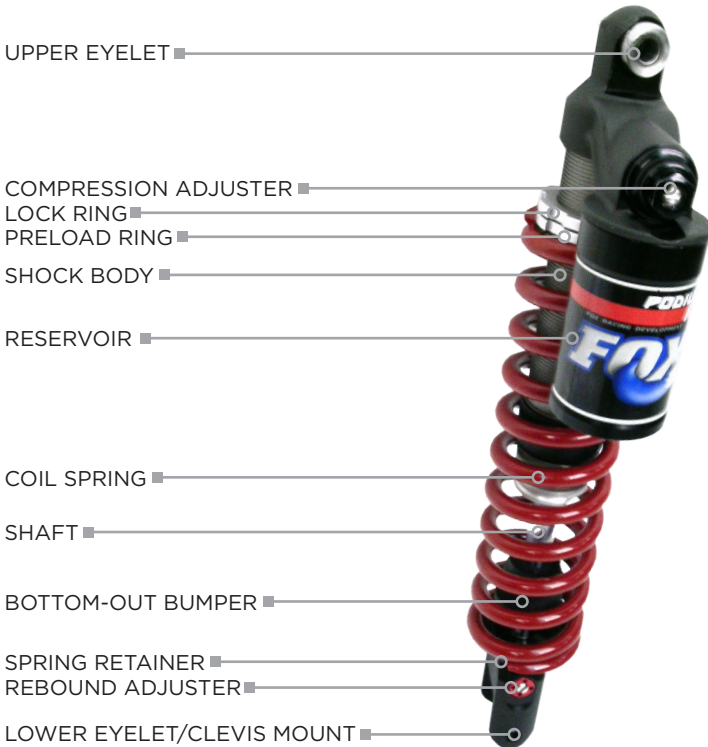

CONGRATULATIONS!

Thank you for choosing FOX PODIUM X for your motorcycle. In doing so, you have chosen the finest suspension shock in the world. FOX Racing Shox products are designed, tested and manufactured by the finest professionals in the industry in Santa Cruz County, California, USA.

As a consumer and supporter of FOX Racing Shox products, you need to be aware of the importance of setting up your shock correctly to ensure maximum performance. This manual provides step-by-step instructions of how to setup and maintain your shock. It is a good idea to keep your receipts with this manual, and refer to it for service and warranty issues.

This manual does not contain step-by-step detailed service instructions for a reason: FOX recommends that detailed service be performed by FOX Racing Shox or a qualified suspension professional.

CONSUMER SAFETY



RIDING A MOTORCYCLE CAN BE DANGEROUS AND CAN RESULT IN DEATH OR SERIOUS INJURY.

Take your responsibility to yourself and others seriously, and heed the following safety tips:

- > Keep your motorcycle and suspension system in optimal working condition.
- > Wear protective clothing, eye protection and always fasten your helmet before you ride.
- > Know and ride within your limits.

The PODIUM X shock contains a nitrogen charge. The charged portion of the shock should only be opened by a FOX Racing Shox technician or a qualified suspension professional.



OPENING A NITROGEN PRESSURIZED SHOCK CAN BE DANGEROUS AND CAN RESULT IN SERIOUS INJURY OR DEATH.

SETTING UP THE PODIUM X

CHANGING SPRINGS

1. Loosen the lock ring and spring preload ring until the spring freely moves up and down on the body.
2. Lift up the spring and remove the spring retainer.
3. Slide the spring off the shock body over the shaft end (eyelet/clevis end). Depending on your motorcycle model, you may need to remove the reducers to remove the spring.
4. Orient the new spring correctly (see **SPRING ORIENTATION** on next page) and slide it onto the shock body.
5. Place the spring retainer back on the shock and under the spring ensuring that the open slot on the spring retainer rests on the flat part of the spring end.
6. Tighten the preload ring approximately four (4) turns to take up any free play of the spring against the retainer and preload ring.
7. Adjust preload according to the **ADJUSTING SPRING PRELOAD** section on page 7.

READING THE SPRING RATE

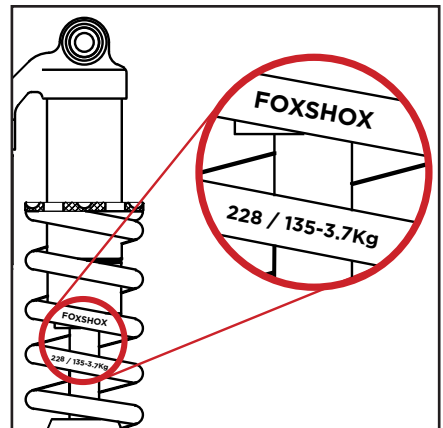

The spring rate is printed directly on the shock spring. The spring above is 228mm in free length, and has a 3.7Kg/mm spring rate and 135mm of travel.

SPRING ORIENTATION

When placing the spring back on the shock body, it is important that the spring is correctly oriented. Essentially, the space in the spring retainer should rest on the flat part of the spring, and not on the segment of the spring where it starts to coil back under itself. Rotate the spring or spring retainer until the correct orientation is achieved.



AN IMPROPERLY ORIENTED SPRING CAN FAIL PREMATURELY, CAUSING LOSS OF CONTROL OF THE MOTORCYCLE, WHICH CAN RESULT IN SERIOUS OR FATAL INJURIES.

The pictures below demonstrate correct and incorrect spring orientation:

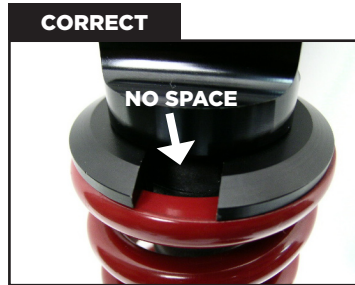
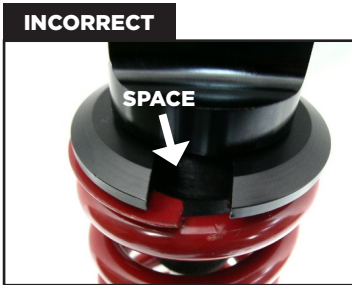

Spring should sit flat across the spring retainer gap.

MOUNTING THE PODIUM X

Refer to your motorcycle's owner's manual for the specific tools required for your motorcycle brand.

For preload adjustment on the PODIUM X you will need: a large long flatblade screwdriver or punch, hammer and regular flatblade screwdriver for compression/rebound adjustments.

1. Place the motorcycle on a workstand.

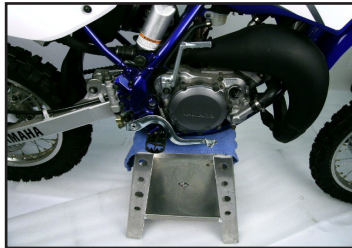

2. As applicable, remove the seat, side panels, silencer, and subframe/airbox from your motorcycle. Refer to your motorcycle's owner's manual for specific information on accessing your rear shock mount.



3. Remove upper and lower shock mounting hardware and remove the stock shock.



TAKE NOTE OF THE ORIENTATION AND WIDTHS OF THE STOCK MOUNTING HARDWARE, SUCH AS UPPER & LOWER EYELETS OR CLEVIS MOUNTS. THIS WILL HELP WHEN INSTALLING THE PODIUM X SHOCK AND ITS ACCOMPANYING REDUCER & O-RING SET.

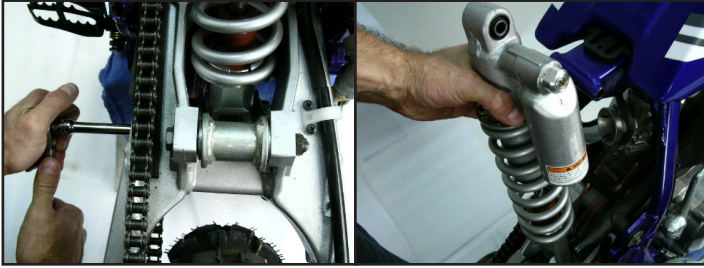

4. Install the PODIUM X, ensuring that the upper reducers and o-rings are in the correct position (see drawing below).

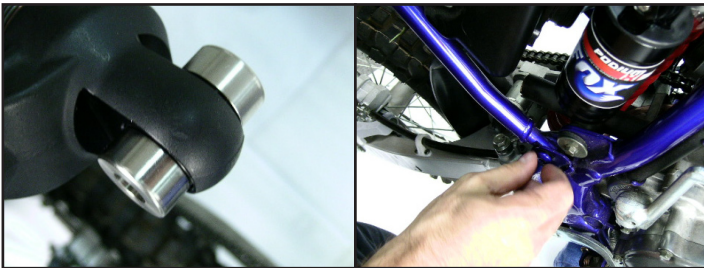
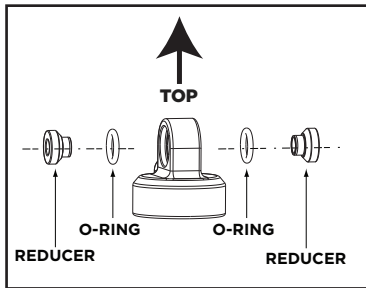

RM85: THE CLEVIS CUTAWAYS MUST FACE THE LINK OR THE PODIUM X SHOCK WILL NOT MOUNT.



YZ85: REBOUND ADJUSTER ON THE PODIUM X MUST FACE THE REAR OF THE BIKE.

5. Install upper and lower shock mounting hardware and torque according to the specifications listed in your motorcycle's owner's manual.



IF YOUR SPECIFIC APPLICATION UTILIZES A LOWER CLEVIS MOUNT, A SMALL DROP OF BLUE LOCTITE® ON THE THREAD IS RECOMMENDED DURING INSTALLATION.



6. Re-install seat, side panels, silencer, and subframe/airbox on your motorcycle.



7. Set rider sag and free sag on the PODIUM X as indicated in the following sections.

MEASURING AND SETTING RIDER SAG

To get the best performance from your PODIUM X, it is necessary to adjust sag. Sag is how much the shock compresses, or “sags,” when you sit on the motorcycle. Use the following procedure to measure rider sag:

1. On a level surface, place the bike on a stand with its wheels off the ground. This ensures that the rear suspension is fully extended before measuring **S1** in the next step. Your shock should be properly installed.



ENSURE THAT YOUR MOTORCYCLE'S SUSPENSION AND PIVOTS ARE LUBRICATED AND IN GOOD WORKING ORDER. “STICKY” BEARINGS OR LINKAGES WILL YIELD INACCURATE MEASUREMENTS.

2. Measure the distance from the rear axle to a fixed point on the side panels above the axle. It is helpful to mark the fixed point with a piece of tape or marker. This is **RIDER SAG MEASUREMENT #1**, extended length (**S1**). See the picture **S1** on the next page.
3. Remove the motorcycle from the stand and sit on the motorcycle in normal riding position with your riding gear on, and have an assistant push down the seat or rear fender approximately 1”. Allow the rear suspension to return to a neutral position.
4. Have an assistant measure and record the distance from the rear axle to the same fixed point used in step 2. This is **RIDER SAG MEASUREMENT #2 (S2)**. See the picture **S2** on the next page.

$S1 - S2 = \text{RIDER SAG}$

- Consult the **SAG RECOMMENDATION** table below and find the recommended rider sag.
- If the rider sag measurement is too little, decrease spring preload (see **ADJUSTING SPRING PRELOAD** on the next page), then repeat step 4 until proper sag is achieved.

If the rider sag measurement is too much, increase spring preload (see **ADJUSTING SPRING PRELOAD** on the next page), then repeat step 4 until proper sag is achieved.

SAG RECOMMENDATION	Recommended Sag	
Motorcycle Description	Rider Sag (mm)	Free Sag (mm)
85cc Linked rear suspension	90	20 - 30
65cc Linked rear suspension	80	15 - 25
50cc/65cc Linkless rear suspension (e.g., KTM)	75	10 - 20
85cc Super mini / Big wheel	95	20 - 30

MEASURING AND SETTING FREE SAG

Free sag should only be checked after checking rider sag, and is used to determine if your spring rate is correct for your weight. If the free sag is less than the recommended values, the spring rate is too low—you will need to obtain a higher rate spring. Conversely, if the free sag is greater than the recommended values, your spring rate is too high and you will need to obtain a lower rate spring.

Use the following procedure to measure free sag:

- With the shock installed on your bike and the bike on a stand (this ensures that the rear suspension is fully extended), measure the distance from the rear axle to a fixed point on the side panels or rear fender above the axle. It is helpful to mark the fixed point with a piece of tape or marker. This is **FREE SAG MEASUREMENT #1 (F1)**. See the picture **F1** on the next page.
- Remove the motorcycle from the stand and push down the seat or rear fender approximately 1". This allows the suspension to return and rest in a neutral position.
- Measure the distance from the center of the rear axle to the same fixed point used in step #1. This is **FREE SAG MEASUREMENT #2 (F2)**. See the picture **F2** on the next page.

 $F1 - F2 = \text{FREE SAG}$

- Consult the **SAG RECOMMENDATION** table on the previous page and find the recommended free sag.



F1

F2

- If your free sag falls outside the recommended range, you will need to change your spring rate.



ALL SPRINGS ARE AVAILABLE THROUGH FOX RACING SHOX. CONSULT THE CONTACT INFORMATION ON THE INSIDE BACK COVER.

ADJUSTING SPRING PRELOAD

- Using a regular screwdriver or punch, turn the lock ring on the PODIUM X shock counterclockwise (looking down on the shock) to unlock the preload ring. You may also need to use a hammer to strike the screwdriver/punch and loosen the lock ring.
- Turn the preload ring clockwise to increase spring preload.
 - Turn the preload ring counterclockwise to decrease spring preload.
- After the proper preload has been set, turn the lock ring clockwise until it engages the preload ring. Using a hammer, strike the screwdriver/punch to securely fasten the lock ring.
- Measure and set sag by following the steps in the **MEASURING AND SETTING RIDER SAG** section on page 5.



IF MORE THAN 5 FULL TURNS ARE REQUIRED TO ACHIEVE PROPER SAG, YOU NEED TO OBTAIN A HIGHER RATE SPRING.

TUNING THE PODIUM X

Go out and ride. Tune your senses to what the motorcycle's rear end is doing. Sometimes you know the bike isn't handling quite right but, for example, it may be hard to tell whether the problem is too little rebound damping or too much compression damping. Sometimes the difference in "feel" is subtle.

Some of the distinctions are minute. If the damping doesn't seem quite right, make your best guess as to what change will help, then try it. If handling doesn't improve, make another change in the opposite direction. Keep experimenting like this until the ride feels best.

It is common practice for riders to "test" shock absorber damping two ways. One way is to stroke the shock in and out by hand and notice the damping resistance. The other way is to push down on the back of the bike (seat or rear fender) and observe the shock response. These tests are useful, but very limited. You should be aware that these tests only involve low-speed damping action. They tell you nothing about shock response at medium and high shaft speeds. It is important to realize this when tuning your shocks. Remember that, with these two tests, you will be able to notice tuning changes that affect low-speed damping. But you will not be able to notice the changes that affect high-speed damping.

TUNING RECOMMENDATIONS

The percentage change in damping when going from one click to the next click is fairly small. This is so you can really fine tune your shock. A one click change is hard to notice. Therefore, FOX recommends making changes of two clicks at a time. For example, if after testing you feel compression is too soft, try a two-click change (clockwise on compression adjuster). If that feels just right, then you've got it. On the other hand, if that now feels a little too stiff, then you've got it "bracketed"; go back one click (counterclockwise) and it should now feel just right.

These recommendations apply to both rebound and compression damping.



IF YOU WANT TO KNOW YOUR CURRENT SETTING, BOTH ADJUSTERS SHOULD BE BASELINED BY TURNING THEM CLOCKWISE AND COUNTING THE NUMBER OF CLICKS UNTIL THE ADJUSTER LIGHTLY BOTTOMS. DO NOT OVERTIGHTEN.

REBOUND DAMPING

Rebound damping controls the rate at which the shock returns after it has been compressed. The proper rebound setting is a personal preference, and changes with rider weight, riding style and conditions. A rule of thumb is that rebound should be as fast as possible without kicking back and pushing the rider off the saddle.

The rebound screw (see picture on right) is located on the shaft end of the shock, and is adjusted using a screwdriver.

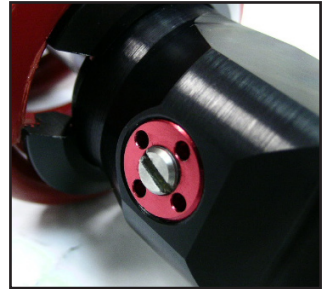

REBOUND ADJUSTER SCREW

For slower rebound, use a screwdriver to turn the adjuster screw clockwise.

For faster rebound, use a screwdriver to turn the adjuster screw counterclockwise.

REBOUND DAMPING TROUBLESHOOTING

Symptom	Remedy
- Bucking - Tops out too hard	Set slower rebound
- Packing in repetitive bumps - Chatter	Set faster rebound

Symptoms of Too Much Rebound Damping

Rear end tends to washout or slideout on hard-packed sweeper turns with small bumps—especially off-camber “washboard” turns. Rear end skips too much when braking on “washboard” sections—does not develop good braking power. Poor rear wheel traction when accelerating over small repetitive bumps (washboard) sections.

Rear end gets harsh and hard to control when hitting series of medium or large rolling bumps at high speed. First few bumps in the series don't seem bad, but after that the rear end gets harsh and starts jumping around.



TOO MUCH DAMPING PREVENTS THE WHEEL FROM EXTENDING QUICKLY ENOUGH BEFORE HITTING THE NEXT BUMP (PACKING). AFTER THE FIFTH OR SIXTH BUMP, YOU MAY HAVE MINIMAL TRAVEL LEFT.

Symptoms of Too Little Rebound Damping

These symptoms are similar to the ones in the previous section: tendency to slideout on washboard turns and poor braking over washboard sections. The critical difference in this case is that the back of the bike is bouncing up and down too much, whereas with too much damping it had poor traction. Too much kicking up especially when braking on downhill sections with small bumps or washboard surface.

Rear end kicks up when hitting large rolling-type bumps at high speeds. Kick-up is especially noticeable on steep downhills with deep rolling bumps. Also, the rear end of the bike may kick up after landing a jump.



THE SHOCK WILL EXTEND TOO QUICKLY IF THERE IS NOT ENOUGH DAMPING TO CONTROL THE SPRING EXTENSION FORCE.

COMPRESSION DAMPING

Compression damping controls the rate at which the shock compresses when it encounters a bump. The proper compression setting is a personal preference and changes with rider weight, riding style and conditions.

To turn the compression adjuster screw, use a screwdriver.

For more compression, turn the compression adjuster clockwise.

For less compression, turn the compression adjuster counterclockwise.



COMPRESSION ADJUSTER SCREW

COMPRESSION DAMPING TROUBLESHOOTING

Symptom	Remedy
- Rigid, harsh ride	Set less compression
- Bottoms-out easily	Set more compression

Symptoms of Too Much Compression Damping

Rear end is harsh over small bumps. Shock seems to stay almost rigid instead of absorbing bumps. Especially noticeable on downhill bumps.

Rear end is harsh at high speeds over large or medium square-edged bumps. The shock stays too rigid and does not use enough travel to absorb bumps. The shock rarely or never seems to bottom-out, even off the biggest jumps.

Symptoms of Too Little Compression Damping

Shock bottoms-out on medium-sized bumps and the bottom of deep, smooth gullies, or rising portions of deep, rolling sand whoops.

At high speed the rear end takes medium square-edged bumps smoothly, but bottoms out too easily on larger bumps. Bottoms out too easily off jump and at high speeds over large square-edged bumps, kicking up the rear end violently.

INSPECTING AND MAINTAINING THE PODIUM X

Proper inspection and maintenance procedures are crucial to maintaining the high performance and durability of your FOX PODIUM X shock. Proper inspection and maintenance now prevent headaches and equipment failure later, not to mention lackluster performance at the races and your absence from the podium.

You should clean your PODIUM X before and after every ride for optimal performance. Use a mild detergent and rag to clean off any and all debris from your shock. Be sure to clean the area located under the bottom-out bumper as well.

Along with properly cleaning your shock, you should also inspect the following areas before every ride. Consult the shock picture below for the location of each inspection location:

#1: Check the reducers and o-rings for excessive wear or damage.

#2: Check the reservoir for any signs of damage.

#3: Check the piston shaft for any signs of leakage or damage.

#4: Check the spring and shock body for any signs of damage.

#1 & #5: Check the motorcycle's and the shock's mounting points and make sure all bolts are properly fastened.



YOUR PODIUM X SHOCK IS CHARGED WITH NITROGEN. SPECIAL EQUIPMENT IS NECESSARY TO ACCESS AND ALTER THE NITROGEN CHARGE.



IN THE UNLIKELY EVENT THAT YOU NEED TO RETIRE YOUR PODIUM X SHOCK, CONTACT FOX RACING SHOX FOR PROPER DISPOSAL.



TUNING NOTES:

QUICK REFERENCE GUIDE

PODIUM X

terms used

SUSPENSION

- > **Compression:** downward travel of the suspension. Actions that move the endpoints of the shock closer together.
- > **Compression damping:** oil damping resistance felt when trying to compress the shock.
- > **Emulsion shock:** shock without an IFP (Internal Floating Piston) separating the oil and nitrogen.
- > **Frame clearance:** distance between the frame and other moving parts, like the shock.
- > **Negative travel:** distance the suspension or shock extends from the static ride height. Also referred to as 'free sag'.
- > **Preload:** initial force on the spring. Preload is used to adjust rider sag.
- > **Ride height:** with the rider on the bike, the basic stance of the bike. Usually measured from the ground to some point on the bike frame.
- > **Rebound:** force required to extend the shock or suspension. Can also refer to the extending action of the suspension.
- > **Rebound damping:** oil damping resistance that controls the rate at which the shock extends after being compressed.
- > **Rider sag:** amount the shock compresses with the rider sitting on the bike in a normal riding position. Best measured with a friend holding your cycle up.
- > **Free sag:** amount that the bike "sits" into travel. Usually measured from the ground to a point on the frame, or as shock stroke, and without a rider on the bike.
- > **Stroke:** amount of shock travel.
- > **Travel:** total amount the shock compresses, as measured from eye-to-eye.
- > **Wheel travel:** distance the wheel moves when the suspension is cycled through its full travel.

RIDING

- > **Bottoming:** vehicle has bottomed-out when the suspension reaches the limit of its travel and stops further downward motion.
- > **Bucking:** kicking motion on a rider after a bump or jump landing.
- > **Chatter:** small bumps similar to braking bumps prior to a corner or berm. Often refers to the harshness felt when riding over small, closely spaced bumps.
- > **Fading:** slow loss of shock damping usually due to heat.
- > **Packing:** when the shock does not return quickly enough to adequately absorb the next bump in a repetitive bump sequence.
- > **Spiking:** sharp impact cause by a square-edge bump.
- > **Squat:** when the rear of the vehicle "sits" down either due to weight transfer or driveline forces.
- > **Stiction:** initial force that needs to be overcome to start the suspension stroke.
- > **Topping-out:** when the suspension is fully extended.

SHOCK

- > **Eyelets:** at either end of the shock where the shock mounts to the bike.
- > **Spring rate:** force required to compress a spring one inch. Measured in lb/in. or Kg/mm.
- > **Valving:** refers to the combination of shims or damping valves on the piston face used to achieve a specific ride characteristic.

service intervals

- > **Before every ride:** Wipe mud and debris off shock exterior
- > **Monthly:** Check your shock's spring retainers
- > **Annually:** Clean and inspect your shock. See the **INSPECTING AND MAINTAINING THE PODIUM X** section on page 9 of this manual.
- > **Every ride season:** Shock rebuild by a FOX Certified Technician or FOX Racing Shox

tools and supplies

- > Flat-blade screwdriver
- > Large Phillips screwdriver
- > Ratchet
- > Rebuild Kit 803-00-128
- > FOX Light Racing Oil 025-05-001

contact info

FOX Racing Shox
130 Hangar Way
Watsonville, CA 95076
USA
Phone: 1.831.274.6500
North America: 1.800.FOX.SHOX (369.7469)
Fax: 1.831.768.7026
E-mail: mcyc@foxracingshox.com
Website: www.foxracingshox.com
Business hours: Monday - Friday 8 a.m. - 5 p.m. PST

method of payment & shipping

Visa,
MasterCard,
Cashier's Check

FOX Racing Shox uses UPS Ground Service within the USA.

disclaimer

FOX Racing Shox is not responsible for any damages to you or others arising from riding, transporting, or other use of your PODIUM X shock. In the event that your shock breaks or malfunctions, FOX Racing Shox shall have no liability beyond the repair or replacement of your shock pursuant to the terms outlined in the warranty provisions of this manual.

specific exclusions from warranty

- > Parts replaced due to normal wear and tear and/or routine maintenance
- > Parts subject to normal wear and tear and/or routine maintenance
- > Bushings
- > Seals (after the 90-day seal warranty period expires)
- > Suspension fluids
- > Crash damage

warranty policy

The factory warranty period for your shock is one year (two years for countries in the EU) from the original date of purchase of the shock or motorcycle. A copy of the original purchase receipt must accompany any shock being considered for warranty service. Warranty is at the full discretion of FOX Racing Shox and will cover only defective materials and workmanship. Warranty duration and laws may vary from state to state and/or country to country.

general exclusions from warranty

- > Installation of parts or accessories not qualitatively equivalent to genuine FOX Racing Shox parts.
- > Abnormal strain, neglect, abuse and/or misuse
- > Accident and/or collision damage
- > Modification of original parts
- > Lack of proper maintenance
- > Shipping damages or loss (purchase of full value shipping insurance is recommended)
- > Damage to interior or exterior caused by rocks, crashes or improper installation
- > Oil changes or service not performed by FOX Racing Shox or an Authorized Service Center

Parts, components and assemblies subject to normal wear and tear are not covered under this warranty.

FOX Racing Shox reserves the right to all final warranty or non-warranty decisions.

valving guarantee

If it is determined that a PODIUM X requires a valving change within the first 90 days of ownership, FOX will perform the re-valve at no charge for the original consumer. The consumer is required to follow the Service Policy procedure below and is responsible for all shipping costs to and from FOX Racing Shox. Unless otherwise specified, FOX Racing Shox will return ship the shock(s) via UPS Ground Service.

service policy

- > FOX Racing Shox offers 5-business day turnaround, which may vary.
- > Obtain an RA (Return Authorization) number and shipping address from FOX Racing Shox at 800.FOX.SHOX. Outside the USA, contact the appropriate International Service Center.
- > Mark the RA number and Return Address clearly on the outside of the package and send to FOX Racing Shox (see Contact Info above) or your International Service Center with shipping charges pre-paid by the sender.
- > Proof-of-purchase is required for warranty consideration.
- > Include a description of the problem, motorcycle information (manufacturer, year and model), type of FOX product and return address with daytime phone number.

© FOX FACTORY 2005 | P/N: 605-00-062

FOX FACTORY INC

130 HANGAR WAY
WATSONVILLE, CA
95076

PH 800.FOX.SHOX FAX 831.768.7026 email MCYC@FOXRACINGSHOX.COM

WWW.FOXRACINGSHOX.COM