

FILL INDICATED REGIONS APPROX 75% FULL WITH STA-LUBE SL3125 BLUE HI-TEMP GREASE.

SECTION A-A
SCALE 4:1

Spring: [0.190 TLG X 0.120 OD X 25.6 lbs/in] 17-7 SS, left hand wound

039-00-264
GREASE:
THIN LAYER
BLUE HI-TEMP

010-01-000
Ball [Ø 0.1250] Steel

039-00-494
Spring: Torsion, 2020 SuperStrut, Zinc Plated

210-30-120
Cam: Compression Adjust, Remote, 2020 SuperStrut

019-01-128
Flat-Head Socket Cap Screw, [M3 x 10 mm], Black Zinc

TORQUE:
11±3 IN-LBF

210-24-606
Cable Hanger: 2020 SuperStrut Remote, Die Cast

TORQUE:
8±2 IN-LBF

019-01-134
Set Screw [M4 x .7mm x 4mm] Flat Point, Torx, Black,

A. ADJUST SET SCREW SO PULLEY SLIDES PARTIALLY ON CAM SHAFT BUT DOES NOT ROTATE.
B. ROTATE PULLEY CLOCKWISE UNTIL PULLEY HAS PASSED THE HARD STOP AND PUSH PULLEY FULLY ONTO SHAFT.
C. TORQUE SET SCREW.

TORQUE:
HAND TIGHT

210-24-460
Rebound Knob, 2020 SuperStrut

019-01-070
Set Screw [M4 x .7mm x 4mm], Flat Point, SS

210-24-461
Pulley, Compression Adjust, 2020 SuperStrut

213-07-164
Eyelet, Collar, 2020 SuperStrut

010-00-057
Air Valve Parts: Cap, Air Valve [L.305-32], Black, 6061

802-00-007-KIT
Tank Valve, Slim [M6 x .75]

TORQUE:
35±5 IN-LBF

029-08-082
Seals: O-Ring [5.28mm ID X 1.0mm CS] Metric, N-70, Static

INSTALL M3 SET SCREW SO TOP SURFACE IS FLUSH WITH EXTERIOR OF EYELET. SET SCREW MUST NOT PROTRUDE INTO EYELET ADJUSTER BORE.

019-01-017
Screw [M3 x .5mm x 3mm], SS, Cup Point, Nylock Patch

Eyelet, 2020 SuperStrut

GREASE:
BLUE HI-TEMP
AS PER [2]

029-08-178
Seals: O-Ring [30.0mm X 1.5mm CS] Metric, N-70, Static

029-08-079
Seals: O-Ring [7.5MM ID x 1.5MM CS] Metric, N-70, Static

GREASE:
THIN LAYER
OF SLICK HONEY

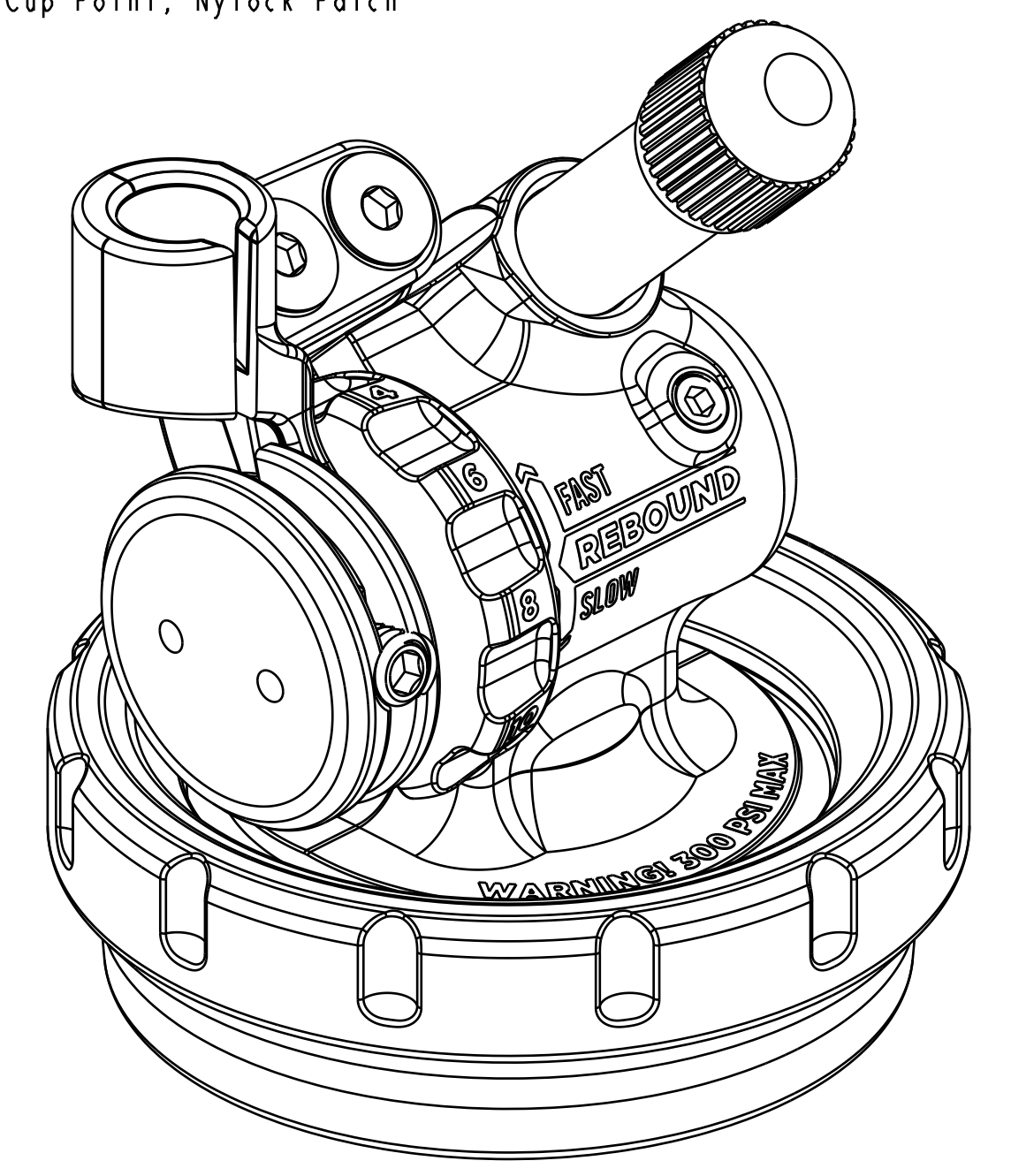

PROPRIETARY - THIS DOCUMENT CONTAINS CONFIDENTIAL, PROPRIETARY INFORMATION THAT IS FOR PROPERTY. DO NOT DISCLOSE TO OR DUPLICATE FOR OTHERS EXCEPT AS AUTHORIZED BY FOX.

		Ph 831-768-1100 Fax 831-768-9312
TITLE Eyelet Assy, 2020 SuperStrut, Remote		
SIZE DWG. NO. D 808-17-398-KIT		
PLOT SCALE 3:1	SHEET 1 OF 1	