

4

3

2

1

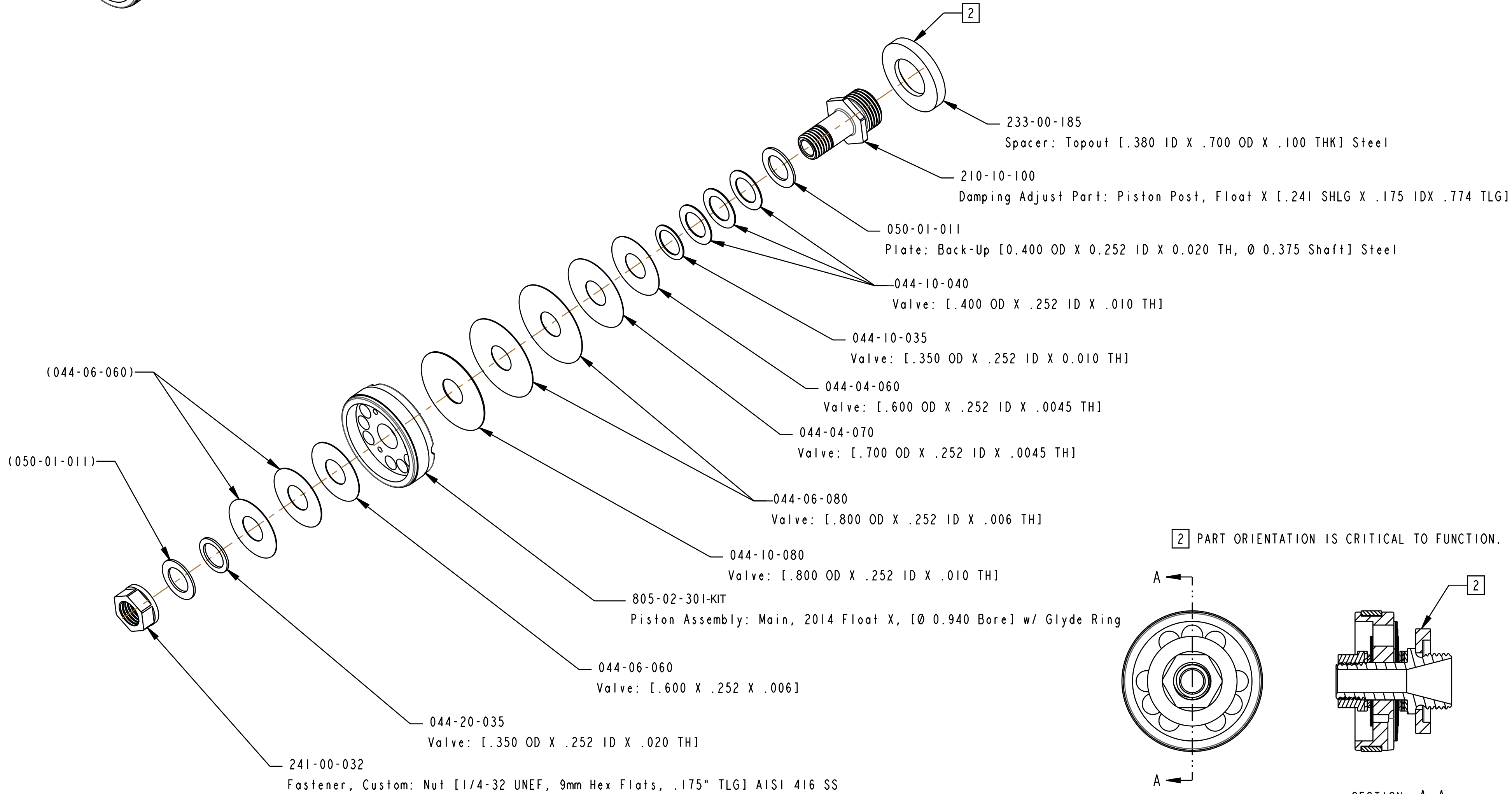
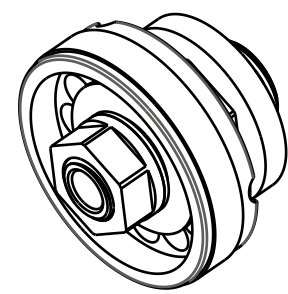

2 PART ORIENTATION IS CRITICAL TO FUNCTION.

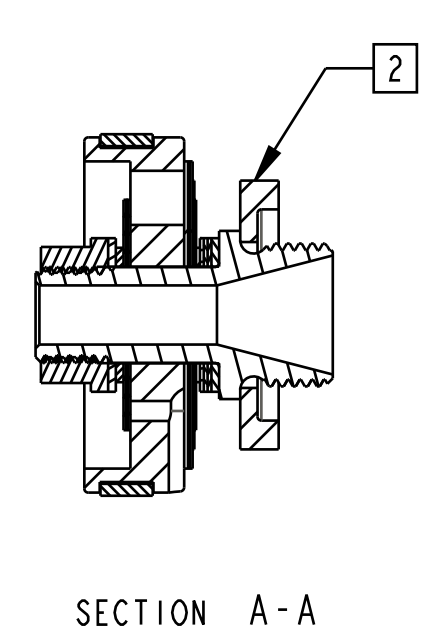
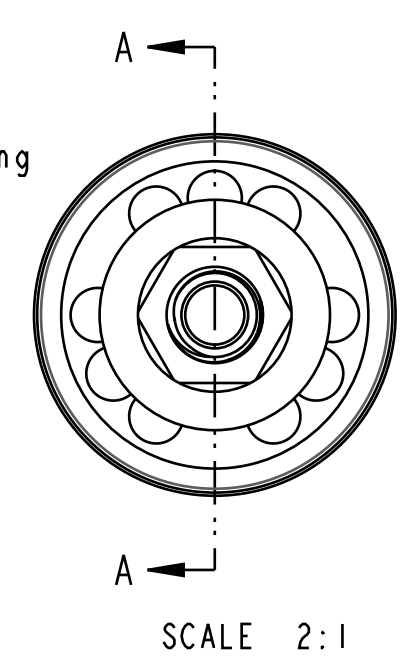

- PROPRIETARY -
 THIS DOCUMENT CONTAINS CONFIDENTIAL, PROPRIETARY INFORMATION
 THAT IS FOX PROPERTY. DO NOT DISCLOSE TO OR DUPLICATE
 FOR OTHERS EXCEPT AS AUTHORIZED BY FOX.

		FOX Factory, Inc. 130 Hangar Way, Watsonville, CA 95076 USA Ph 831-768-1100 Fax 831-768-9312
Valving Assy: 2016 FLOAT X, CXF, RM		
TITLE C	DWG. NO. 807-72-210-KIT	SHEET 1 OF 1
SIZE C	PLOT SCALE 1.5:1	ProE ASSEM

4

3

2

1

ProE ASSEM