

IMPORTANT:
NOTE ORIENTATION OF SEAL

IMPORTANT:
SIZE BUSHING AND 100% CHECK
WITH GO AND NO-GO PIN GAGES:
GO PIN GAGE: $\varnothing .500$
NO GO PIN GAGE: $\varnothing .501$

GREASE:
THIN LAYER OF SLICK HONEY ON
ID AFTER ASSEMBLY

SECTION A-A
SCALE 8:1

Seals: Scraper, $\varnothing .500$ " Shaft, Polyurethane P5065A88, 2022 DHX, G2

Bearing Housing: 2022 DHX, G2

Seals: U-Cup, $\varnothing .500$ " Shaft, NBR 90A, 2022 DHX

Bearing: [.500 ID X .500 TLG X $\varnothing .498$ Shaft]

O-Ring (-022) [.070 C.S. X .989 ID]

GREASE:
THIN LAYER OF SLICK HONEY ON
ID AFTER ASSEMBLY

GREASE:
THIN LAYER OF SLICK HONEY

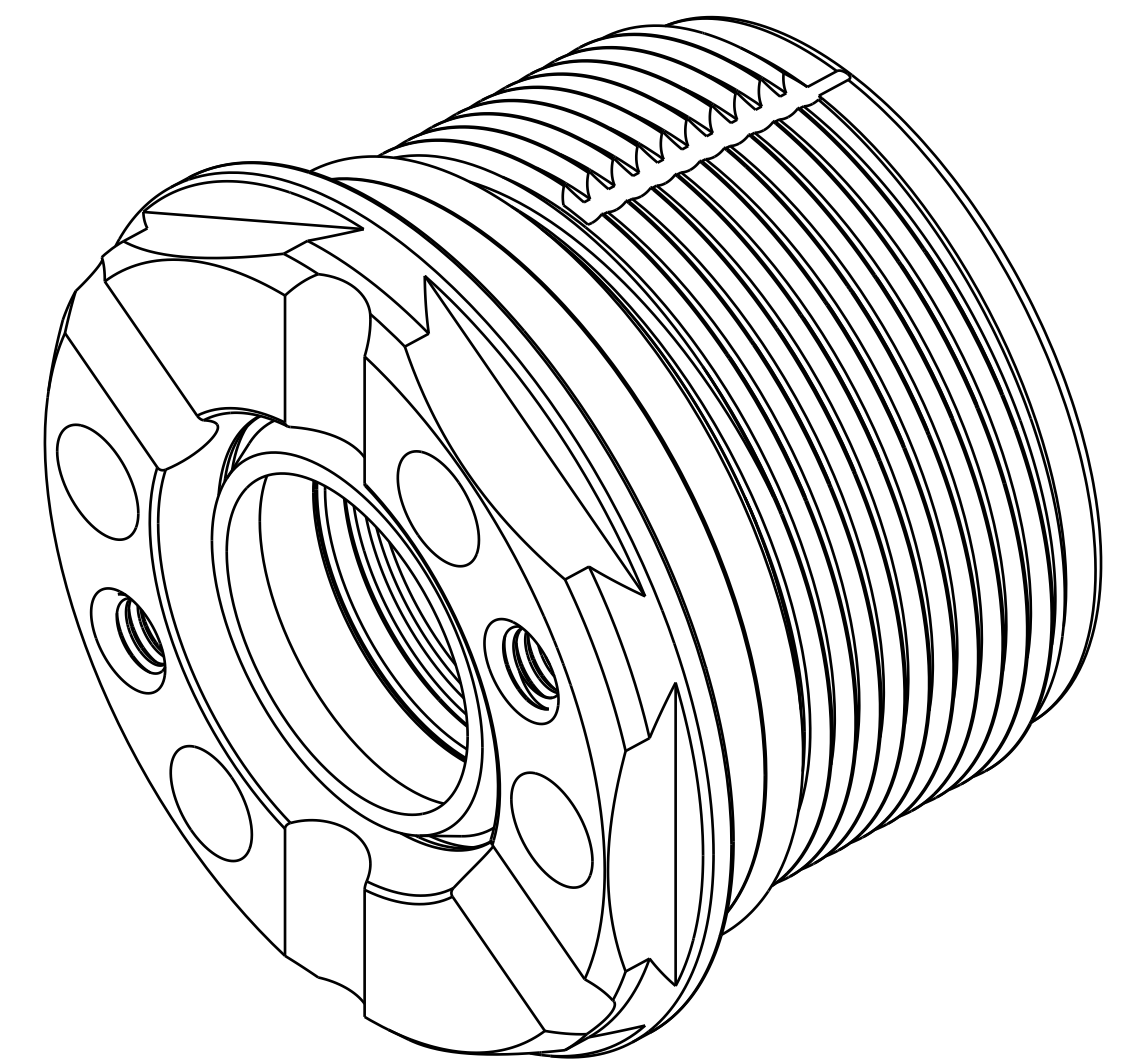

		Ph 831-768-1100 Fax 831-768-9312
TITLE Bearing Housing Assy: 2022 DHX		
SIZE DWG. NO. D 812-06-109-KIT		
PLOT SCALE 4:1	SHEET 1 OF 1	

PROPRIETARY - THIS DOCUMENT CONTAINS CONFIDENTIAL, PROPRIETARY INFORMATION THAT IS FOR PROPERTY. DO NOT DISCLOSE TO OR DUPLICATE FOR OTHERS EXCEPT AS AUTHORIZED BY FOX.