

Spring: [0.190 TLG X 0.120 OD X 25.6 lbs/in] 17-7 SS, left hand wound

010-01-000
Ball [Ø 0.1250] Steel

OIL:
THIN LAYER
OF FLOAT FLUID

TORQUE:
35±5 IN.LB.

TORQUE:
TO CAM SHAFT
AND BACK 1/4 TURN

019-02-021
Set Screw: Custom Dog Point, Radius [M3 x .5mm, .300 TLG], SS

Eyelet: 2013 FLOAT CTD, LV, 6061-T6, Black Ano III

GREASE:
THIN LAYER
HI-TEMP GREASE (BLUE)

802-00-007-KIT
Air Valve Assy: Slim [M6 X .75, 1.150 TLG]

010-00-025
Cap, Air Valve, Short [1.305-32] Black

029-08-079
Seals: O-Ring [7.5MM ID x 1.5MM CS] Metric, N-70, Static

029-00-032
Seals: O-Ring [(-032) .070 C.S. X 1.864 ID] Standard N674-70, Dynamic

TORQUE:
5±1 IN.LB.

019-01-018
Socket Set Dog Point [M3 x .5mm x 6mm]

210-30-056
Cam: CD Adj, 2016 Float DPS, 3pos

GREASE:
THIN LAYER
HI-TEMP GREASE (BLUE)

210-30-044
Damp Adj Part: Knob, RD Adj, 2013 FLOAT CTD Perf And Evol

210-15-080
Damp Adj Part: Lever, CD Adj, 2016 Float DPS, 3pos, No Etch

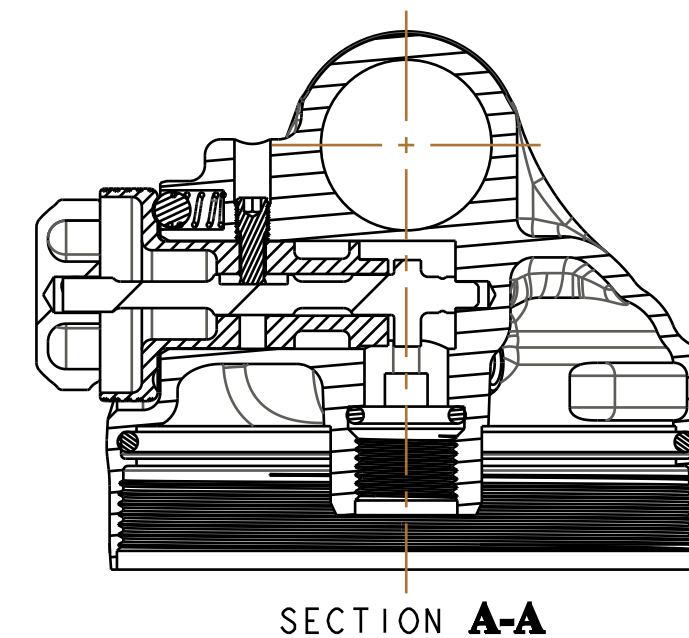
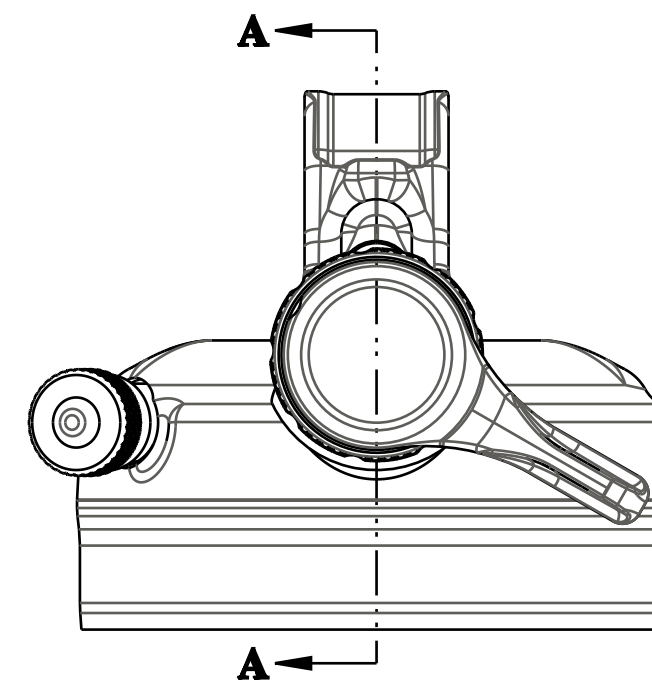

SECTION A-A

PROPRIETARY -
THIS DOCUMENT CONTAINS CONFIDENTIAL, PROPRIETARY INFORMATION
THAT IS FOX PROPERTY. DO NOT DISCLOSE TO OR DUPLICATE
FOR OTHERS EXCEPT AS AUTHORIZED BY FOX.

		FOX Factory, Inc.	Ph 831-768-1100
		130 Hangar Way, Watsonville, CA 95076 USA	Fax 831-768-9312
TITLE			
Eyelet Assy: 2016 FLOAT DPS, 3pos, LV			
SIZE	DWG. NO.	808-17-203-KIT	
C			
PLOT SCALE	3/2	SHEET 1 OF 1	