

4

3

2

1

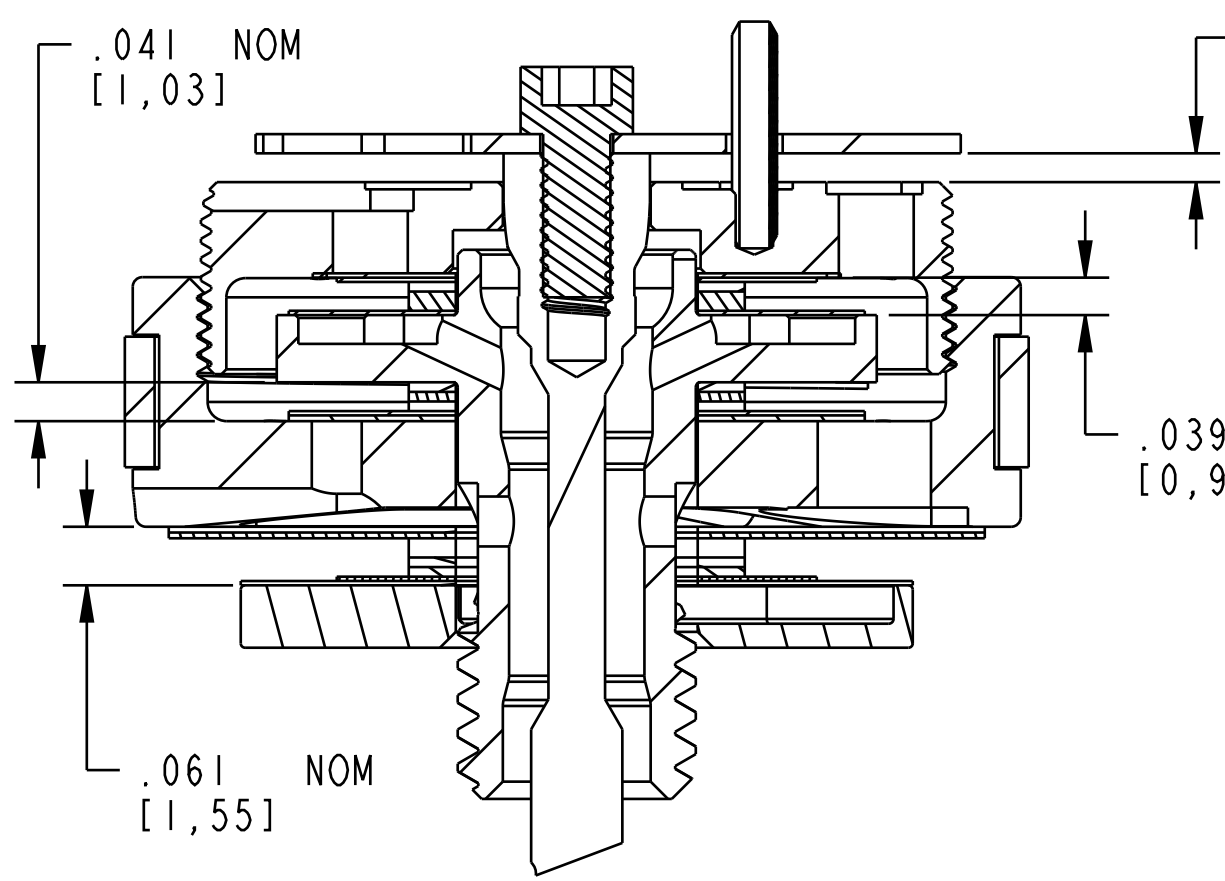

222-01-316
Piston: Lockout, Float DPS [1.200 TLG, M20 X 0.5] 416SS

044-04-055
Valve: [0.550 OD X 0.252 ID X 0.0045 TH]

210-10-104
Piston Bolt: Dish WRD w/ check [1/4-28 X 5/8 Hex]

TORQUE:
22±2 IN.LB.
Custom socket: 398-00-638

(044-10-035) [4]

(044-04-060)

(044-10-035) [3]

044-06-060
Valve: [.600 X .252 X .006]

TORQUE:
60±5 IN.LB.
Custom Socket: 398-00-637

044-04-050
Valve: [.500 OD X .252 ID X .0045 TH]

(044-20-035) [4]

(044-06-085)

044-10-035
Valve: [.350 OD X .252 ID X 0.010 TH]

044-04-060
Valve: [.600 OD X .252 ID X .0045 TH]

(044-10-035) [2]

805-02-031
Piston Assembly: 2016 Float DPS, [Ø 0.940 Bore] w/ Glyde Ring

- NOTES: (UNLESS OTHERWISE SPECIFIED)
1. SHOCK SHOULD HAVE 12-15 REBOUND CLICKS
 - [2] 1 OR 2 SPACERS MAY BE ADDED OR REMOVED TO ADJUST NUMBER OF REBOUND CLICKS .030" MIN SPACING
 - [3] 1 OR 2 SPACERS MAY BE ADDED OR REMOVED TO ADJUST NUMBER OF REBOUND CLICKS .010" MIN SPACING
 - [4] 1 OR 2 SPACERS MAY BE ADDED OR REMOVED TO ADJUST LOCKOUT PLATE LIFT .010" MIN SPACING
 - [5] USE .030-.047 LIFT SPEC FROM CLOSED TO OPEN FOR REMOTES WITH 210-30-090 CAM (TREK)

044-20-035 [2]
Valve: [.350 OD X .252 ID X .020 TH]

044-10-035 [2]
Valve: [.350 OD X .252 ID X 0.010 TH]

044-04-050
Valve: [.500 OD X .252 ID X .0045 TH]

044-04-070
Valve: [.700 OD X .252 ID X .0045 TH]

210-10-098
Damping Adjust Part: Float MY2013 Check Piston [1.740 OD X .252 ID X .110 TH]

FOX FOX Factory, Inc. Ph 831-768-1100
130 Hangar Way, Watsonville, CA 95076 USA Fax 831-768-9312

TITLE
**Valving Assy: 2017 Float DPS,
R/C, CL, RM, CMF [1.940 Bore]**

PROPRIETARY
THIS DOCUMENT CONTAINS CONFIDENTIAL, PROPRIETARY INFORMATION
THAT IS FOX PROPERTY. DO NOT DISCLOSE TO OR DUPLICATE
FOR OTHERS EXCEPT AS AUTHORIZED BY FOX.

SIZE DWG. NO. **807-06-193-KIT**

PLOT SCALE 2.00:1 SHEET 1 OF 1

4

3

2

ProE ASSEM