

4

3

2

1

D

D

C

C

B

B

A

A

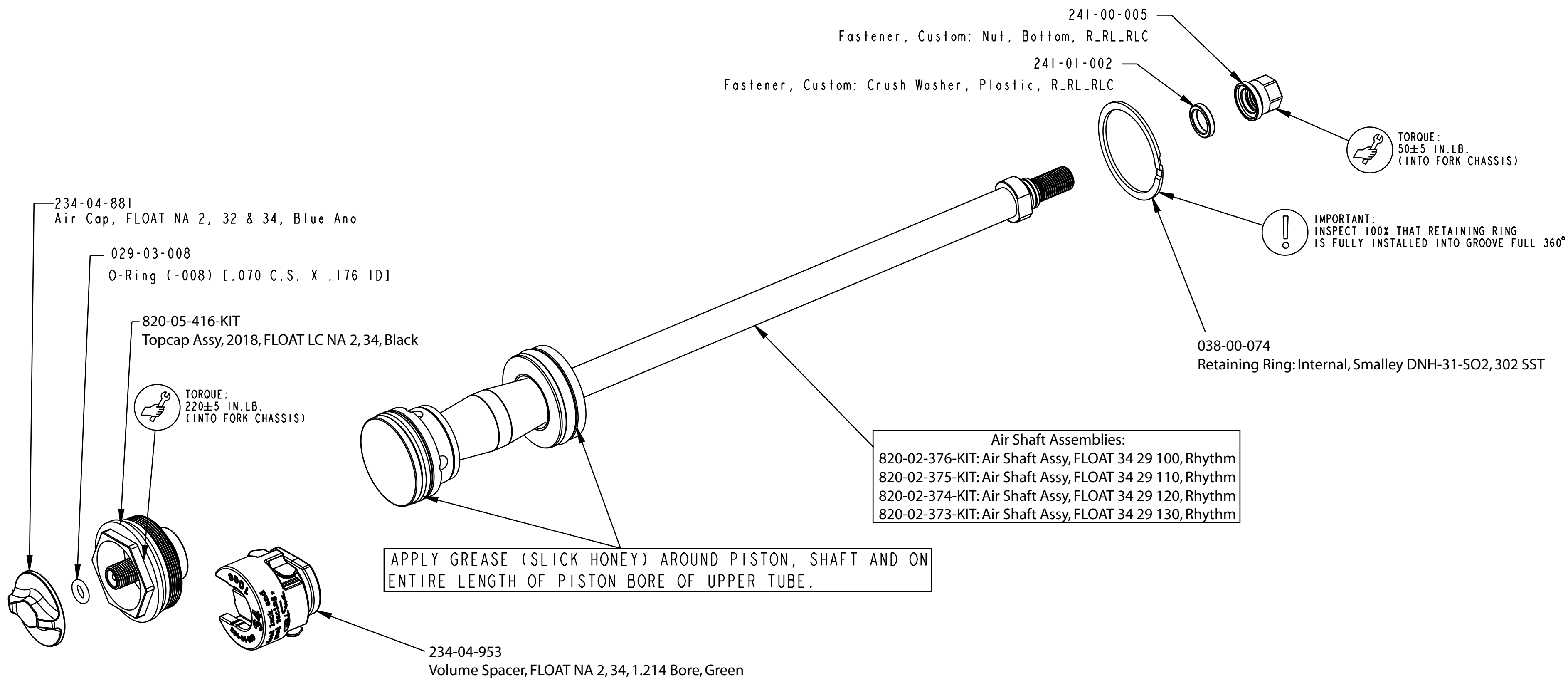

APPLY GREASE (SLICK HONEY) AROUND PISTON, SHAFT AND ON ENTIRE LENGTH OF PISTON BORE OF UPPER TUBE.

Air Shaft Assemblies:
 820-02-376-KIT: Air Shaft Assy, FLOAT 34 29 100, Rhythm
 820-02-375-KIT: Air Shaft Assy, FLOAT 34 29 110, Rhythm
 820-02-374-KIT: Air Shaft Assy, FLOAT 34 29 120, Rhythm
 820-02-373-KIT: Air Shaft Assy, FLOAT 34 29 130, Rhythm

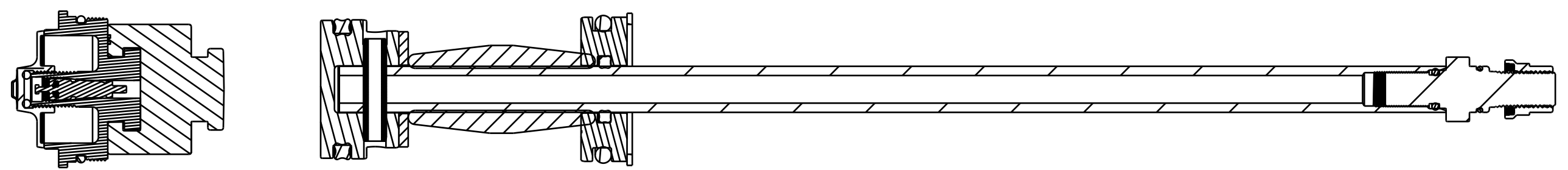

SECTION A-A

- PROPRIETARY -
 THIS DOCUMENT CONTAINS CONFIDENTIAL, PROPRIETARY INFORMATION
 THAT IS FOX PROPERTY. DO NOT DISCLOSE TO OR DUPLICATE
 FOR OTHERS EXCEPT AS AUTHORIZED BY FOX.

FOX		FOX Factory, Inc.	Ph 831-768-1100
		130 Hangar Way, Watsonville, CA 95076 USA	Fax 831-768-9312
TITLE			
2018 34mm Rhythm 29in 100-130			
FLOAT NA2 Air Spring Assemblies			
SIZE DWG. NO.			
C			
PLOT SCALE .00 : 1		SHEET OF	

4

3

2

1

ProE ASSEM