

4

3

2

1

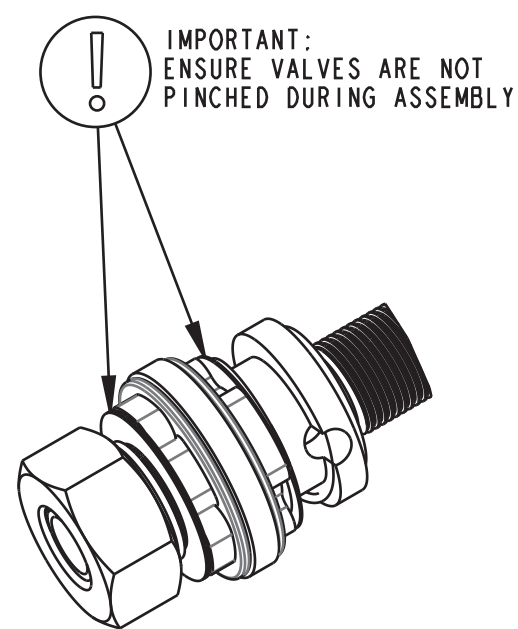

DETAIL A  
SCALE 2:1

Air Valve Parts: Ball [Ø 0.1094] E52100 Grade 25 Steel, Chrome  
Spring: [0.125 TLG X 0.125 OD X 50.00 lbs/in] Music Wire, Zinc plated

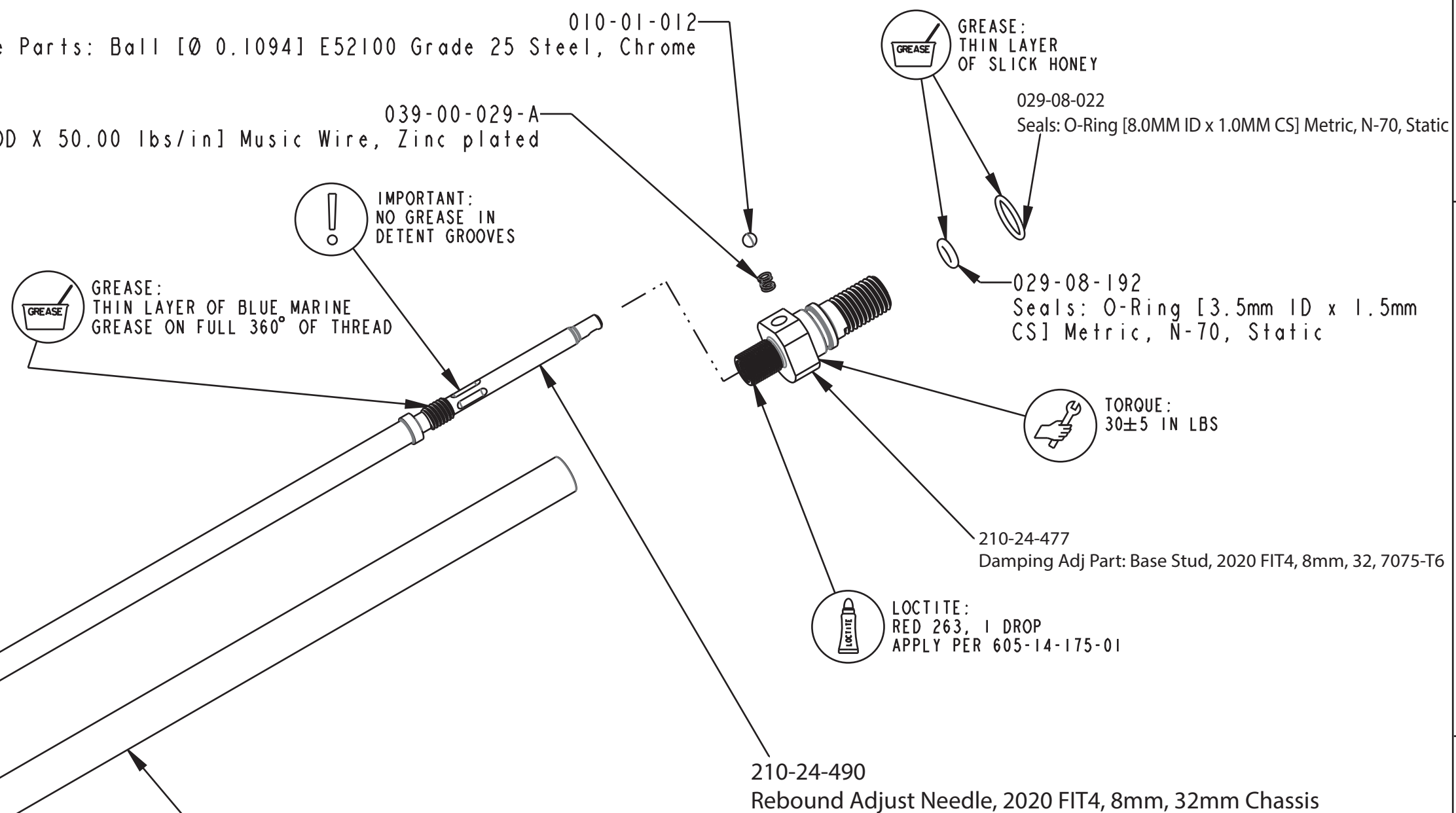

GREASE:  
THIN LAYER  
OF SLICK HONEY

029-08-026  
Seals: O-Ring [2.0mm ID X  
1.5mm CS] Metric, N-60, Static

GREASE:  
THIN LAYER OF BLUE MARINE  
GREASE ON FULL 360° OF THREAD

IMPORTANT:  
NO GREASE IN  
DETENT GROOVES

229-10-633  
Shaft, Damper, 8mm, 2020 FIT4, 32mm Non-SC

SEE DETAIL A

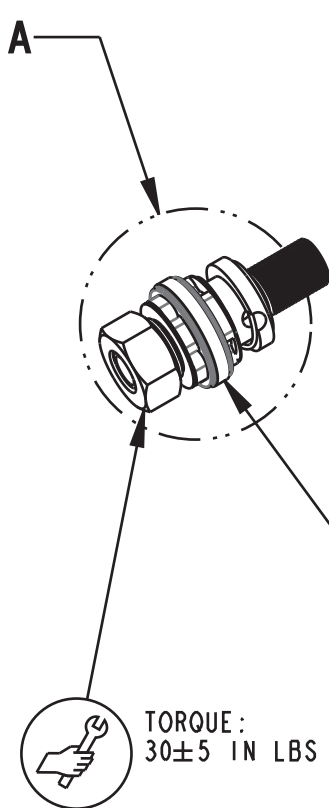

820-03-610-KIT  
2020 FIT4 Rebound Piston Assy, 8mm Shaft

820-03-569-KIT  
Sealhead Assy, 2019 FIT [8mm, M17.56]  
Trelleborg, O-ring

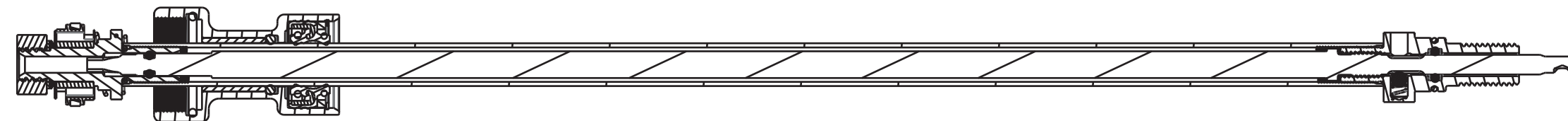

SECTION A-A

PROPRIETARY  
THIS DOCUMENT CONTAINS CONFIDENTIAL, PROPRIETARY INFORMATION  
THAT IS FOX PROPERTY. DO NOT DISCLOSE TO OR DUPLICATE  
FOR OTHERS EXCEPT AS AUTHORIZED BY FOX.

**FOX** **FOX Factory, Inc.** Ph 831-768-1100  
130 Hangar Way, Watsonville, CA 95076 USA Fax 831-768-9312

TITLE  
**2020 32 ALL Non-SC FIT4  
8mm Damper Shaft Assy**

SIZE DWG. NO. **820-03-602-KIT**

PLOT SCALE 1:1 SHEET 1 OF 1

4

3

2

Pr oE ASSEM