

4

3

2

1

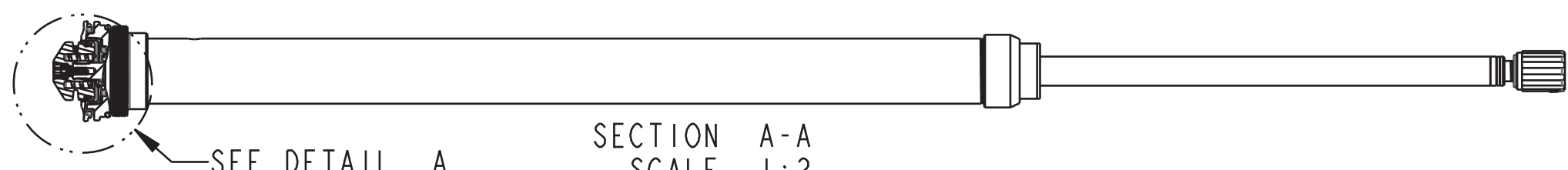

SECTION A-A
SCALE 1:2

SEE DETAIL A

4 PTL

1 PTL

PUSH-TO-LOCK
SECTION C-C

IMPORTANT:
NOTE SEAL ORIENTATION

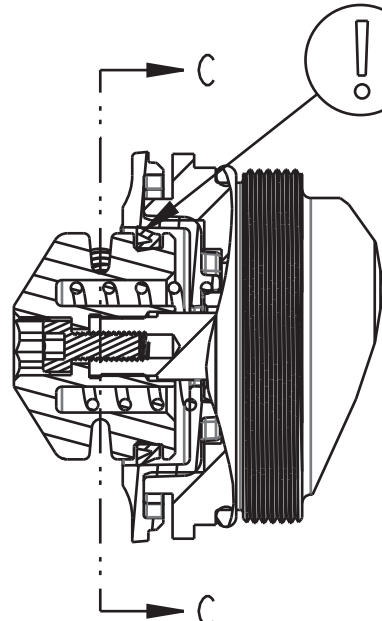

DETAIL A
SCALE 3:2

Fastener, Standard: Screw [#8-32 X 0.250 TLG]

TORQUE:
50±5
(IN-LB)

LOCTITE:
BLUE 243, ONE DROP
APPLY PER 605-14-175-01

TORQUE:
5.0±0.5 IN.LB.

REFERENCE ONLY
(FOR INSTALLATION
INTO FORK)

REBOUND KNOB

241-00-005
Fastener, Custom: Nut, Bottom, R_RL_RLC

820-05-326-KIT
2017 34 29in Grip Bottom Stud Interface Parts

241-01-002-C
Fastener, Custom: Crush Washer, Plastic, R_RL_RLC

1 PTU

4 PTU

PUSH-TO-UNLOCK
SECTION C-C
SCALE 3:2

TORQUE: PUSH-TO-LOCK & PUSH-TO-UNLOCK:
NEEDLE TO 2.0 ± .15 IN-LB BEFORE
INSTALLING TOPCAP INTERFACE PARTS
(SAME TORQUE FOR CARTRIDGE DYNO)

TOPCAP INTERFACE PARTS INSTALL NOTES:

PUSH-TO-LOCK (PTL):

- 1 PTL SUB-ASSEMBLE TOPCAP INTERFACE PARTS WITH PULLEY SET SCREW FACING THE DOT OPPOSITE THE ARROW.
2. INSTALL 1 PTL SUB-ASSY TO DAMPER WITH ARROW FACING DESIRED DIRECTION FOR CABLE ROUTING. TIGHTEN 019-01-148 2-3 TURNS (DO NOT RUN DOWN).
3. ROTATE ENTIRE SUB-ASSY 270° CCW AFTER INSTALLING. CHECK CABLE DIRECTION. TORQUE 019-01-148 WHILE HOLDING PULLEY
- 4 PTL WHEN LOCKED OUT (ADD 5-6 IN-LB CW TORQUE TO PULLEY), SET SCREW MUST BE ALIGNED TO MARK ±20°.
5. PULLEY MUST RETURN FREELY AFTER LOCKOUT (FROM FORCE OF TORSION SPRING ALONE).

PUSH-TO-UNLOCK (PTU):

- 1 PTU SUB-ASSEMBLE TOPCAP INTERFACE PARTS WITH PULLEY SET SCREW FACING THE DOT OPPOSITE THE ARROW.
2. INSTALL 1 PTU PARTS SUB-ASSY TO DAMPER WITH ARROW FACING DESIRED DIRECTION FOR CABLE ROUTING. TIGHTEN 019-01-148 4-5 TURNS (DO NOT RUN DOWN).
3. ROTATE ONLY CABLE HOUSING 270° CW TO PRELOAD TORSION SPRING. CHECK CABLE DIRECTION.
- 4 PTU WHEN LOCKED OUT (STEP 3 COMPLETE, NO EXTRA TORQUE ADDED TO PULLEY), CHECK THAT SET SCREW IS ALIGNED TO MARK ±20°. TORQUE 019-01-148 WHILE HOLDING PULLEY.
5. PULLEY MUST RETURN FREELY AFTER UNLOCK (FROM FORCE OF TORSION SPRING ALONE)

REFERENCE ONLY
(FOR INSTALLATION
INTO FORK)

TORQUE:
220±5 IN.LB.

TORQUE:
(10±1 IN.LB)
REF: FOR BIKE INSTALL

CABLE HOUSING

TOPCAP INTERFACE PARTS:
820-05-611-KIT: 2020 Grip Push-Lock Remote, Topcap Interface Parts
820-05-560-KIT: 2020 Grip PTU Remote, Topcap Interface Parts

TORSION SPRING

GREASE:
THIN LAYER BLUE MARINE GREASE
ID AND OD

Seals: U-Cup, Shore 70A, 2013 CTD-ADJ, Remote Fit-CTD and Remote O/C-CTD

Fastener: Custom (Metric): Set Screw [M4 x .7mm x 3mm] SST, Patchlock

Cable Pulley Remote, 2020 GRIP

Fastener Standard (Metric): Screw [M2.5X8mm] Socket Head Cap, SS

PROPRIETARY -
THIS DOCUMENT CONTAINS CONFIDENTIAL, PROPRIETARY INFORMATION
THAT IS FOX PROPERTY. DO NOT DISCLOSE TO OR DUPLICATE
FOR OTHERS EXCEPT AS AUTHORIZED BY FOX.

FOX FOX Factory, Inc. Ph 831-768-1100
130 Hangar Way, Watsonville, CA 95076 USA Fax 831-768-9312

TITLE
**2021 32 GRIP/RHYTHM REMOTE
CARTRIDGE ASSEMBLIES COMPLETE**

SIZE DWG. NO.

C

PLOT SCALE ~1:1

SHEET 1 OF 1

4

3

2

ProE ASSEM