

**BOTTOM STUD INTERFACE PARTS:**  
 820-05-506-KIT: 2019 34 SC Bottom Stud Interface Parts, 29in Fork  
 820-05-507-KIT: 2019 34 SC Bottom Stud Interface Parts, 27.5in Fork

**TOPCAP INTERFACE PARTS INSTALL NOTES:**

**PUSH-TO-LOCK (PTL):**

- 1 PTL SUB-ASSEMBLE TOPCAP INTERFACE PARTS WITH PULLEY SET SCREW FACING THE DOT OPPOSITE THE ARROW.
2. INSTALL 1 PTL SUB-ASSY TO DAMPER WITH ARROW FACING DESIRED DIRECTION FOR CABLE ROUTING. TIGHTEN 019-01-148 2-3 TURNS (DO NOT RUN DOWN).
3. ROTATE ENTIRE SUB-ASSY 270° CCW AFTER INSTALLING. CHECK CABLE DIRECTION. TORQUE 019-01-148 WHILE HOLDING PULLEY 4 PTL WHEN LOCKED OUT (ADD 5-6 IN-LB CW TORQUE TO PULLEY), SET SCREW MUST BE ALIGNED TO MARK ±20°.
5. PULLEY MUST RETURN FREELY AFTER LOCKOUT (FROM FORCE OF TORSION SPRING ALONE).

**PUSH-TO-UNLOCK (PTU):**

- 1 PTU SUB-ASSEMBLE TOPCAP INTERFACE PARTS WITH PULLEY SET SCREW FACING THE DOT OPPOSITE THE ARROW.
2. INSTALL 1 PTU PARTS SUB-ASSY TO DAMPER WITH ARROW FACING DESIRED DIRECTION FOR CABLE ROUTING. TIGHTEN 019-01-148 4-5 TURNS (DO NOT RUN DOWN).
3. ROTATE ONLY CABLE HOUSING 270° CW TO PRELOAD TORSION SPRING. CHECK CABLE DIRECTION.
- 4 PTU WHEN LOCKED OUT (STEP 3 COMPLETE, NO EXTRA TORQUE ADDED TO PULLEY), CHECK THAT SET SCREW IS ALIGNED TO MARK ±20°. TORQUE 019-01-148 WHILE HOLDING PULLEY.
5. PULLEY MUST RETURN FREELY AFTER UNLOCK (FROM FORCE OF TORSION SPRING ALONE)

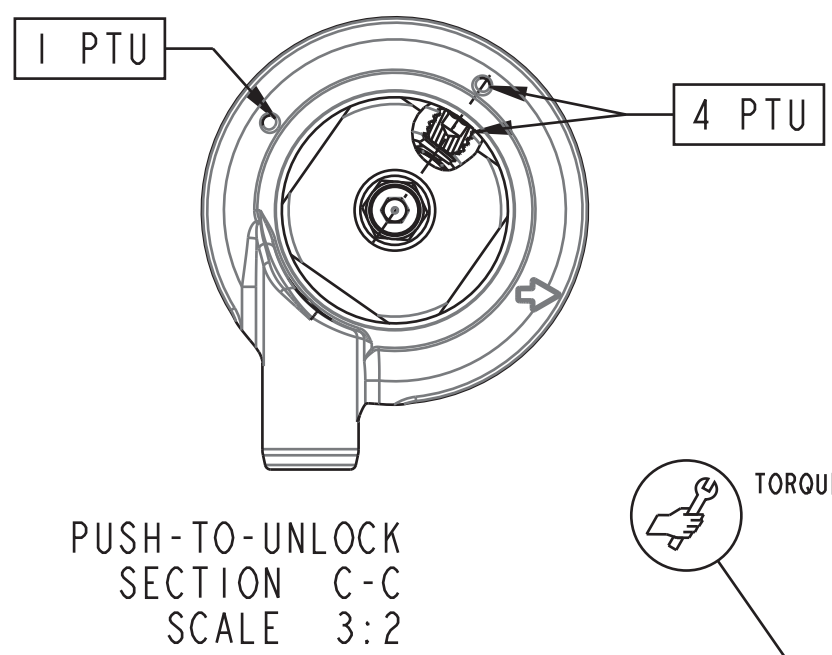

TORQUE: PUSH-TO-LOCK & PUSH-TO-UNLOCK: NEEDLE TO 2.0 ± .15 IN-LB BEFORE INSTALLING TOPCAP INTERFACE PARTS (SAME TORQUE FOR CARTRIDGE DYNO)

TORQUE: 220±5 IN.LB. REFERENCE ONLY (FOR INSTALLATION INTO FORK)

TORQUE: (10±1 IN.LB) REF: FOR BIKE INSTALL

TORQUE: 6±1 IN.LB.

GREASE: THIN LAYER BLUE MARINE GREASE ID AND OD

Seals: U-Cup, Shore 70A, 2013 CTD-ADJ, Remote Fit-CTD and Remote O/C-CTD

Fastener: Custom (Metric): Set Screw [M4 x .7mm x 3mm] SST, Patchlock

Cable Pulley Remote, 2020 GRIP

Fastener Standard (Metric): Screw [M2.5X8mm] Socket Head Cap, SS

CABLE HOUSING

TORSION SPRING

PROPRIETARY - THIS DOCUMENT CONTAINS CONFIDENTIAL, PROPRIETARY INFORMATION THAT IS FOX PROPERTY. DO NOT DISCLOSE TO OR DUPLICATE FOR OTHERS EXCEPT AS AUTHORIZED BY FOX.

**FOX Factory, Inc.** Ph 831-768-1100  
 130 Hangar Way, Watsonville, CA 95076 USA Fax 831-768-9312

TITLE  
**2021 34 SC GRIP REMOTE CARTRIDGE ASSEMBLIES COMPLETE**

SIZE DWG. NO.  
**C**  
 PLOT SCALE ~1:1 SHEET 1 OF 1