

4

3

2

1

Air Valve Parts: Ball [Ø 0.1094] E52100 Grade 25 Steel, Chrome

Spring: [0.125 TLG X 0.125 OD X 50.00 lbs/in] Music Wire, Zinc plated

GREASE:  
THIN LAYER  
OF SLICK HONEY

BASE STUD O-RING

Seals: O-Ring [3.5mm ID x 1.5mm CS] Metric, N-70, Static

TORQUE:  
30±5 IN LBS

BASE STUD

LOCTITE:  
RED 263, 1 DROP

REBOUND NEEDLE

DAMPER SHAFT

Seals: O-Ring [2.0mm ID X 1.5mm CS] Metric, N-60, Static

GREASE:  
THIN LAYER  
OF SLICK HONEY

SEE DETAIL A

820-03-569-KIT  
Sealhead Assy, 2019 FIT [8mm, M17.56]  
Trelleborg, O-ring

820-03-610-KIT  
2020 FIT4 Rebound Piston Assy, 8mm Shaft

TORQUE:  
30±5 IN LBS

IMPORTANT:  
ENSURE VALVES ARE NOT  
PINCHED DURING ASSEMBLY

IMPORTANT:  
NO GREASE IN  
DETENT GROOVES

GREASE:  
THIN LAYER OF BLUE MARINE  
GREASE ON FULL 360° OF THREAD

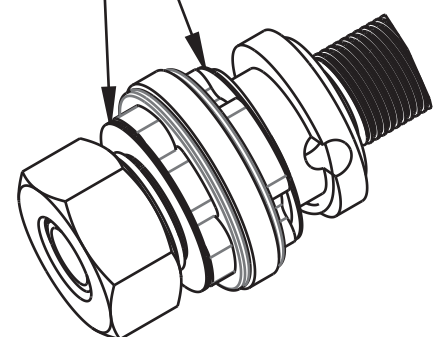

DETAIL A  
SCALE 2:1

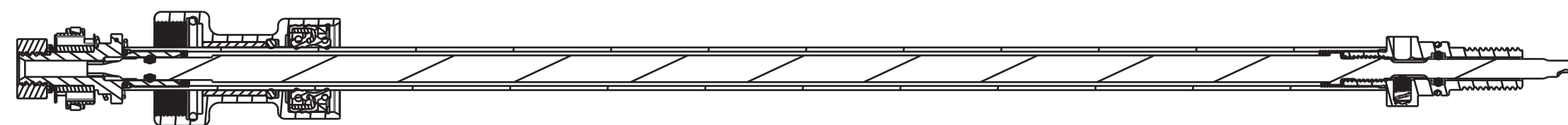

SECTION A-A

**FOX** **FOX Factory, Inc.**  
130 Hangar Way, Watsonville, CA 95076 USA  
Ph 831-768-1100 Fax 831-768-9312

TITLE  
**2020 34 ALL Non-SC FIT4  
8mm Damper Shaft Assy**

SIZE DWG. NO. **820-03-604-KIT**

PLOT SCALE 1:1 SHEET 1 OF 1

PROPRIETARY  
THIS DOCUMENT CONTAINS CONFIDENTIAL, PROPRIETARY INFORMATION  
THAT IS FOX PROPERTY. DO NOT DISCLOSE TO OR DUPLICATE  
FOR OTHERS EXCEPT AS AUTHORIZED BY FOX.

4

3

2

ProE ASSEM